



# The Next Big Theme

GLOBAL X ETFs INSIGHTS

30 May 2026

Global X Investment Strategy Team

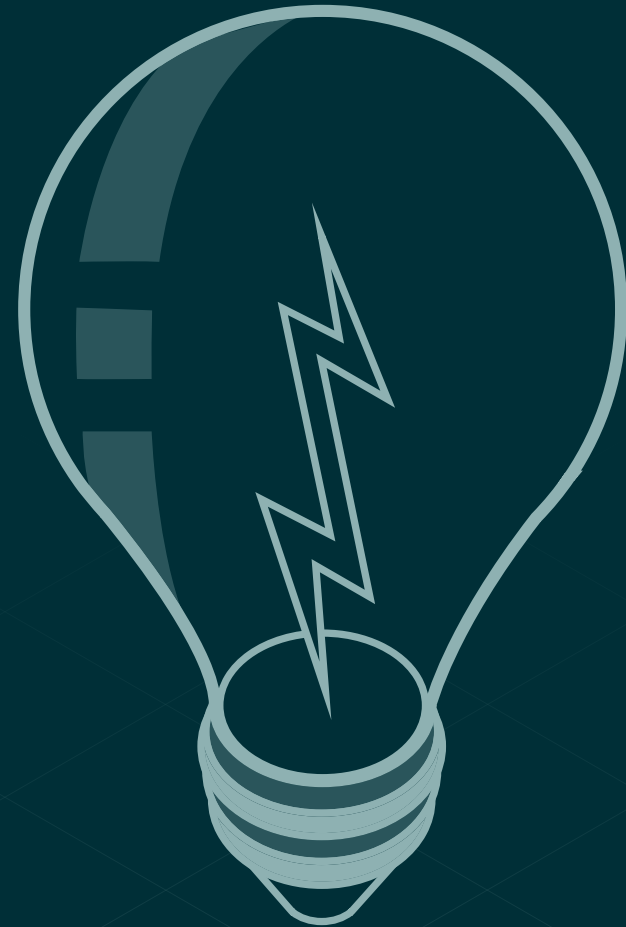

**GLOBAL X**  
by Mirae Asset

Marketing Communication. Capital at Risk. For Professional Investors only.  
Please read fund legal documentation before making any final investment decisions.



# Contents



**03** Monthly Chart Spotlight

**04** U.S. Infrastructure

**05** European Infrastructure

**06** Semiconductors

**07** U.S. Infrastructure

**08** U.S. Electrification

**09** Robotics

**10** Footnotes

**11** Disclaimers



# MONTHLY CHART SPOTLIGHT

## LEADING U.S. HYPERSCALERS INCREASE 2026 CAPEX PLANS PAST \$700 BILLION

Source: Global X ETFs illustration with information derived from Bloomberg (May 2026)

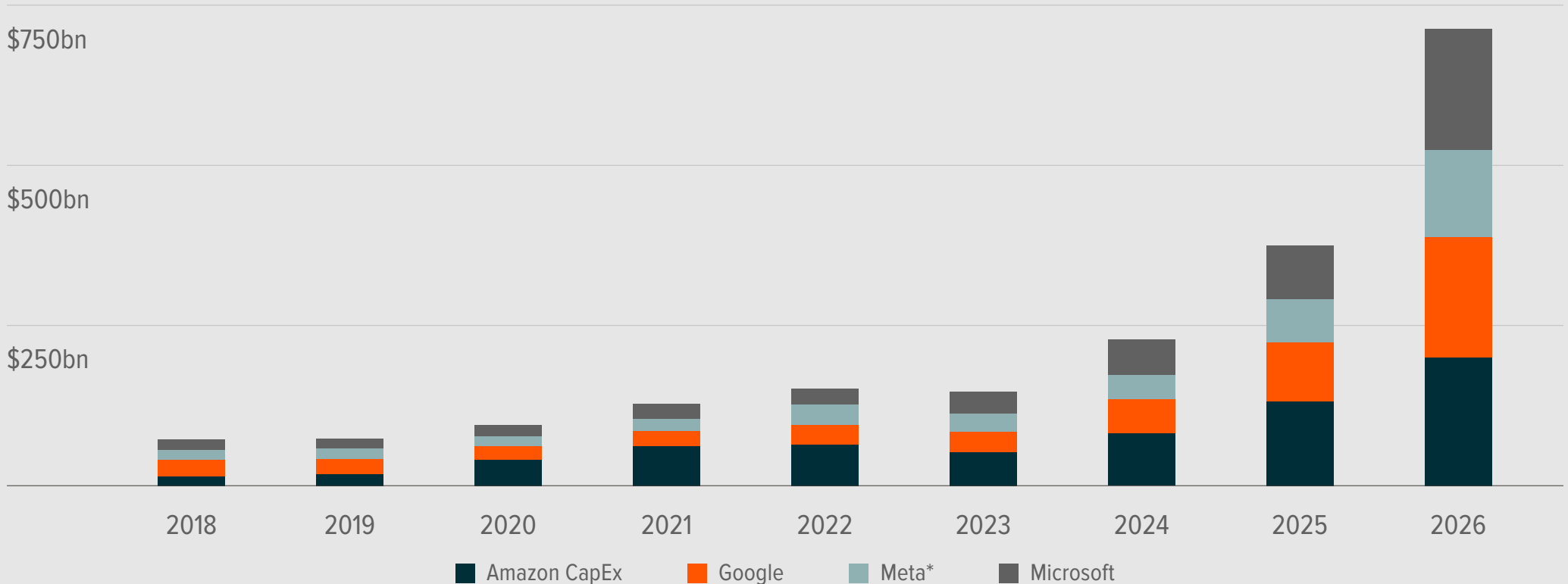

\*2026 figures represent company guidance, Meta's figure is midpoint of estimated range.

There is no guarantee that any trends observed in this material will continue. Any views and opinions are based on current market conditions and are subject to change.



## U.S. INFRASTRUCTURE

# Jacobs awarded EPCM contract to deliver second Hut 8 AI data centre in Texas<sup>1</sup>

Jacobs has been awarded a sole source engineering, procurement and construction management contract by Hut 8 an energy infrastructure platform, to deliver a second U.S. AI data centre campus.<sup>2</sup> The second AI data centre is poised to become one of the largest AI and high-performance computing developments in North America, delivering 245 megawatts of capacity.<sup>3</sup> The contract may also highlight how the accelerating buildout of AI infrastructure is increasingly benefiting U.S. engineering and infrastructure development companies as demand for large-scale data centre capacity continues to grow.<sup>4</sup>

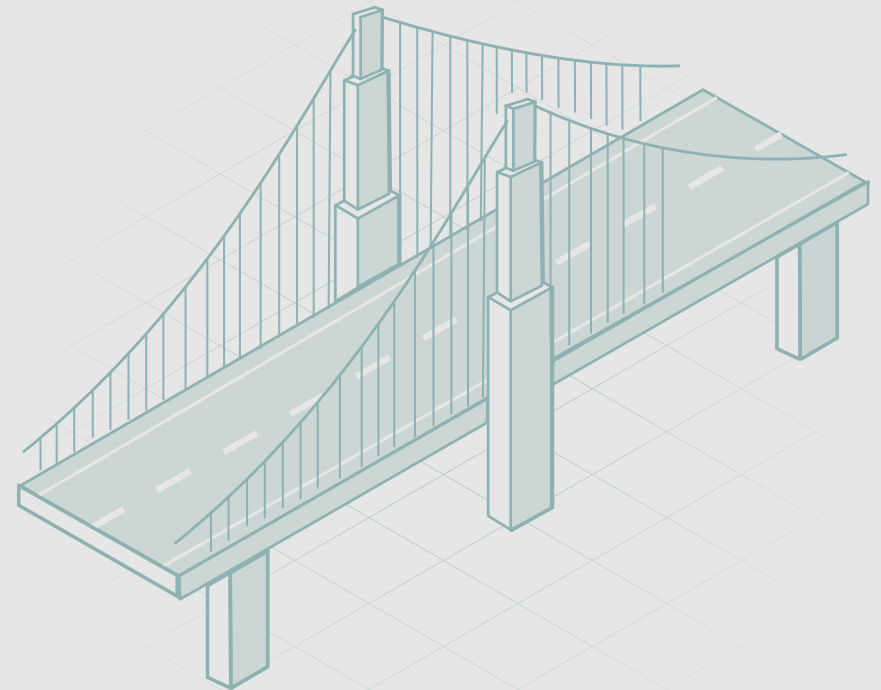

# 245<sub>MW</sub>

Capacity of U.S.'s second AI data centre campus, contracted by Jacobs



## EUROPEAN INFRASTRUCTURE

# HS2 Contract Win for Vinci<sup>5</sup>

Vinci was awarded a £856 million joint venture (JV) contract on the HS2 line via subsidiary Taylor Woodrow, to construct the rolling stock maintenance depot and Network Integrated Control Centre in Birmingham.<sup>6</sup> The new contract follows work won by a JV between Vinci and Balfour Beatty, for earthworks, ground engineering viaducts and tunnels along a 90km stretch of the project.<sup>7</sup> This contract win could demonstrate that companies with sufficient scale and expertise are continuing to win construction work, and in this case, also demonstrates Vinci's pan-European reach.

# £856<sub>m</sub>

Amount awarded to Vinci in a joint venture to construct the rolling stock maintenance depot and Network Integrated Control Centre in Birmingham

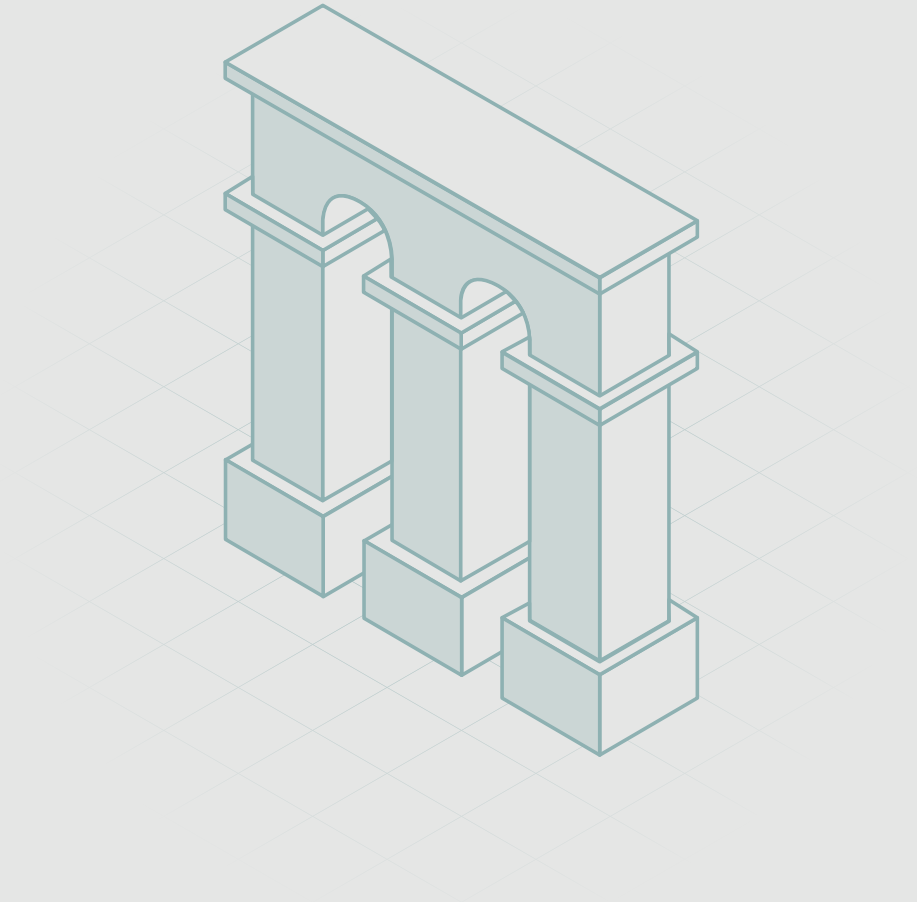



## SEMICONDUCTORS

# Apple reaches preliminary deal with Intel to produce chips<sup>8</sup>

AI demand appears to be reshaping semiconductor manufacturing economics, with AI accelerators increasingly consuming leading-edge chip capacity once dominated by smartphone processors.<sup>9</sup> Reports that Apple may explore Intel Foundry as an alternative to TSMC could also serve to highlight how rising AI infrastructure demand is driving supply-chain diversification and accelerating efforts to build a stronger U.S.-based semiconductor ecosystem.<sup>10</sup>

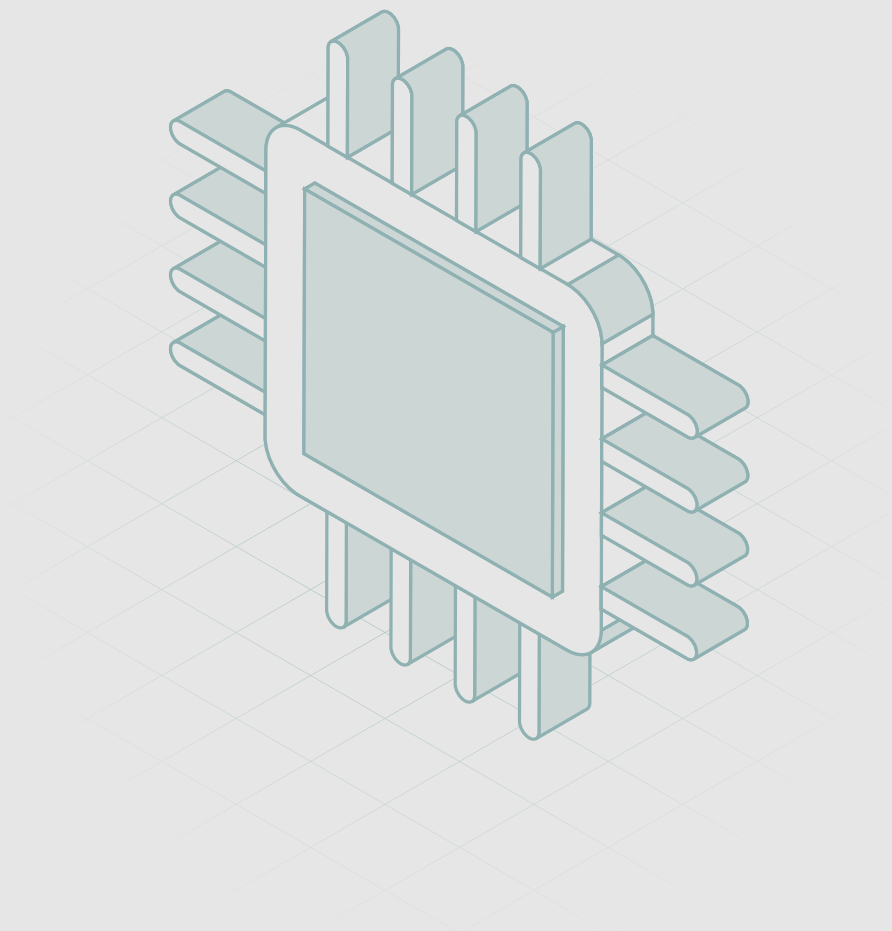



## U.S. INFRASTRUCTURE

# Is Ford's New Energy Storage Subsidiary the Next Big Move in the EV Race?

Ford just unveiled Ford Energy, a new subsidiary focused on U.S.-assembled battery energy storage systems (BESS) for data centres and large industrial customers.<sup>11</sup> Leveraging repurposed EV battery facilities, Ford Energy plans to operate across the full BESS value chain – from cell manufacturing to module and container assembly – with customer deliveries expected to begin in late 2027 and annual deployment capacity targeted at 20GWh.<sup>12</sup>

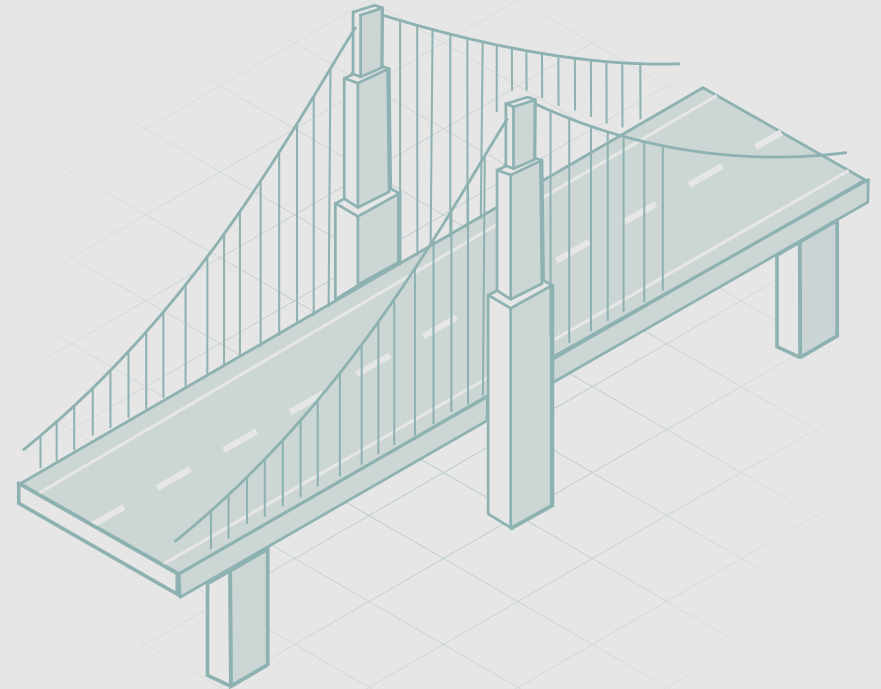

# 20<sub>GWh</sub>

Ford Energy's annual deployment capacity target



## U.S. ELECTRIFICATION

# Could New DOE Funding Accelerate the Next Generation of Nuclear Power?

The U.S. Department of Energy announced \$94 million in funding for eight companies advancing small modular reactor (SMR) development across the U.S. nuclear supply chain.<sup>13</sup> The funding supports key areas needed to commercialise SMRs by the 2030s, including site preparation, equipment assembly, installation, and quality assurance, with Constellation expected to receive \$17.3 million to advance permitting for a potential SMR site in New York.<sup>14</sup>

# \$17.3<sub>m</sub>

Expected amount for Constellation to advance permitting for a potential SMR site in New York





## ROBOTICS

# Fanuc Accelerates the Physical AI Through Collaboration with Google

Fanuc have partnered with Google to build “Physical AI” systems for industrial robots, combining Fanuc’s robot platform with Google Cloud, Gemini Enterprise, Intrinsic’s Flowstate, and Google DeepMind’s Gemini Robotics programme.<sup>15</sup> Fanuc reported it has shipped more than 1,000 robots for Physical AI-related applications, with a Gemini-powered demo system able to understand natural-language instructions, recognise objects, and operate robots autonomously.<sup>16</sup> The deal perhaps signals a broader shift from robotics hardware towards AI-enabled automation systems.<sup>17</sup>

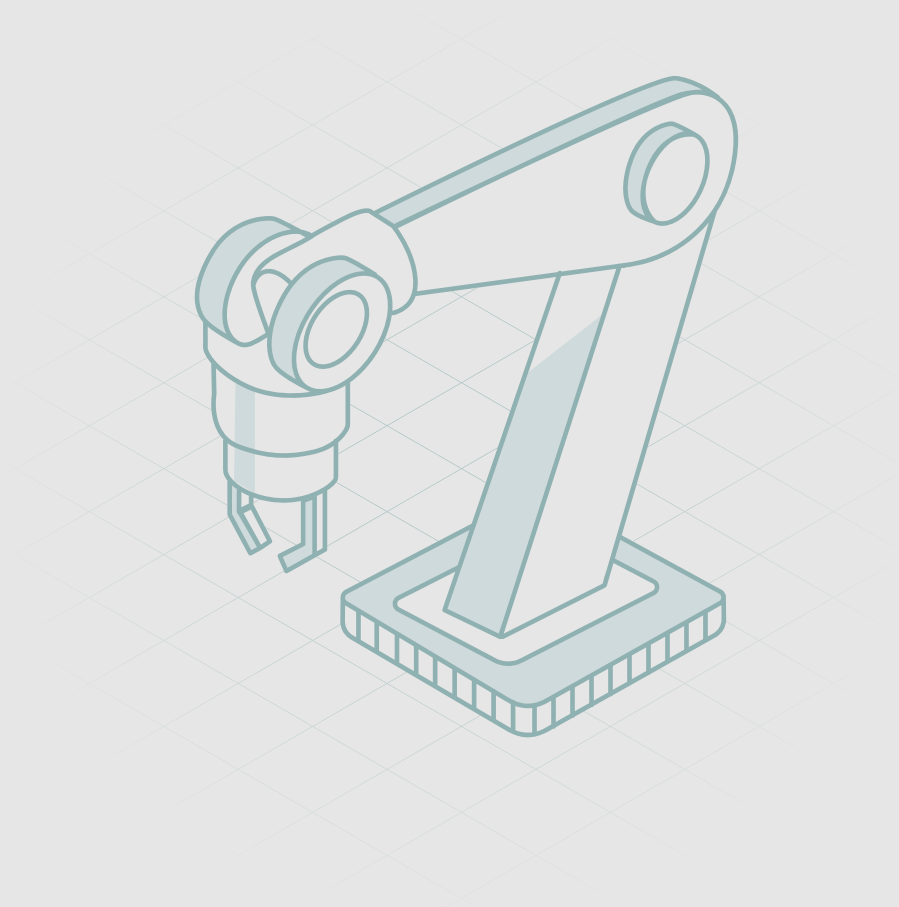

# +1,000

Amount of robots reportedly shipped by Fanuc for Physical AI-related applications



## FOOTNOTES

- 1 Jacobs (Press Release) (May 2026)
- 2 Ibid
- 3 Ibid
- 4 Yahoo! Finance (February 2026)
- 5 Yahoo! Finance (May 2026)
- 6 Ibid
- 7 Balfour Beatty (May 2026)
- 8 Wall Street Journal (May 2026)
- 9 EE Times (May 2026)

- 10 Ibid
- 11 Ford (May 2026)
- 12 ESG Today (May 2026)
- 13 U.S. Department of Energy (May 2026)
- 14 Ibid
- 15 Bloomberg.com (May 2026)
- 16 Investing.com (May 2026)
- 17 Bloomberg.com (May 2026)



## DISCLAIMERS

This document is not intended to be, or does not constitute, investment research as defined by the Financial Conduct Authority

### Important Information – Please Read Carefully

This communication is for Professional Investors only and should not be used with, nor relied upon by, retail clients. It is for use only by the recipient and should not be forwarded to a third party

The Global X UCITS ETFs are regulated by the Central Bank of Ireland.

#### This is a marketing communication.

The UCITS ETFs are index-tracking funds and as such you should read the investment policy of the fund in the supplement to understand how the UCITS ETF will invest.

Please refer to the relevant prospectus, supplement, and the Key Information Document (“KID”) of the relevant UCITS ETFs before making any final investment decisions.

Investors should also refer to the section entitled “Risk Factors” in the relevant prospectus of the UCITS ETFs in advance of any investment decision for information on the risks associated with an investment in the UCITS ETFs, and for details on portfolio transparency. The relevant prospectus and KID for the UCITS ETFs are available in English at [www.globalxetfs.eu/funds](http://www.globalxetfs.eu/funds).

Investment in the UCITS ETFs concern the purchase of shares in the UCITS ETFs and not in a given underlying asset such as a building or shares of a company, as these are only the underlying assets that may be owned by the UCITS ETFs.

A UCITS ETF's shares purchased on the secondary market cannot usually be sold directly back to a UCITS ETF. Investors must buy and sell shares on a secondary market with the assistance of an intermediary (e.g. a stockbroker) and may incur fees for doing so. In addition, investors may pay more than the current net asset value when buying shares and may receive less than the current net asset value when selling them. Changes in exchange rates may have an adverse effect on the value price or income of the UCITS ETF.

Past performance of a UCITS ETF does not predict future returns. Future performance is subject to taxation which depends on the personal situation of each investor, and which may change in the future. Neither past experience nor the current situation are necessarily accurate guides to the future growth in value or rate of return of a UCITS ETF.

Investment may be subject to sudden and large falls in value, and, if it is the case, the investor could lose the total value of the initial investment. Income may fluctuate in accordance with market conditions and taxation arrangements. The difference at any one time between the sale and repurchase price of a share in the UCITS ETF means that the investment should be viewed as medium term to long term.

Any investment in a UCITS ETF may lead to a financial loss. The value of an investment can reduce as well as increase and, therefore, the return on the investment will be variable.

Global X ETFs ICAV is an open-ended Irish collective asset management vehicle issuing under the terms of its prospectus and relevant supplements as approved by the Central Bank of Ireland and is the issuer of certain of the ETFs where stated.

Global X ETFs ICAV II is an open-ended Irish collective asset management vehicle issuing under the terms of its prospectus and relevant supplements as approved by the Central Bank of Ireland and is the issuer of certain of the ETFs where stated.

Communications issued in the European Union relating to Global X UCITS ETFs are issued by Global X Management Company (Europe) Limited (“GXM Europe”) acting in its capacity as management company of Global X ETFs ICAV. GXM Europe is authorised and regulated by the Central Bank of Ireland. GXM Europe is registered in Ireland with registration number 711633.

Communications issued in the United Kingdom and Switzerland relating to Global X UCITS ETFs are issued by Global X Management Company (UK) Limited (“GXM UK”), which is authorised and regulated by the Financial Conduct Authority. The registered office of GXM UK is 77 Coleman Street, London, EC2R 5BJ, UK. Information about GXM UK can be found on the Financial Services Register (Firm Reference Number 965081).

GXM Europe may terminate marketing arrangements.

#### Information for Investors in the United Kingdom

Please refer to the relevant prospectus, supplement, and the Key Investor Information Document (“KIID”) of the relevant UCITS ETFs before making any final investment decisions. These are available in English at [www.globalxetfs.eu](http://www.globalxetfs.eu).

The Financial Ombudsman Service is unlikely to consider complaints relating to the ETF and any claims for losses relating to the manager and the Depository of the ETF are unlikely to be covered under the Financial Services Compensation Scheme.

#### Information for Investors in Switzerland

This is an advertising document. The state of the origin of the fund is Ireland. In Switzerland, the representative is 1741 Fund Solutions AG, Burggraben 16, CH-9000 St.Gallen. The paying agent is Telco Bank AG, Bahnhofstrasse 4, 6430 Schwyz.

The prospectus, the key information documents or the key investor information documents, the articles of association as well as the annual and semi-annual reports may be obtained free of charge from the representative.

Past performance is no indication of current or future performance. The performance data do not take account of the commissions and costs incurred on the issue and redemption of units.