



The Next Big Theme

GLOBAL X ETFs INSIGHTS

26 March 2026

Global X Investment Strategy Team

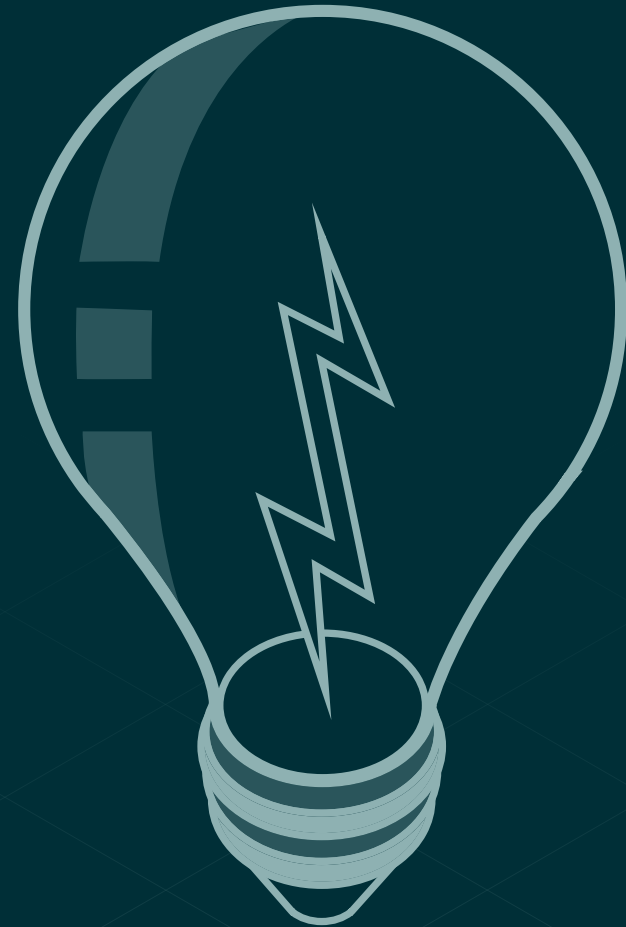

GLOBAL X
by Mirae Asset

Marketing Communication. Capital at Risk. For Professional Investors only.
Please read fund legal documentation before making any final investment decisions.



Contents



- 03 Monthly Chart Spotlight
- 04 European Infrastructure
- 05 European Infrastructure
- 06 Defence Tech
- 07 European Defence Tech
- 08 Robotics & Artificial Intelligence
- 09 Data Centres
- 10 Footnotes
- 11 Disclaimers



MONTHLY CHART SPOTLIGHT

POTENTIAL SPILLOVER EFFECTS OF INCREASED GERMAN INFRASTRUCTURE SPENDING

Source: Global X ETFs illustration with information derived from European Investment Bank Report. (March 2026)

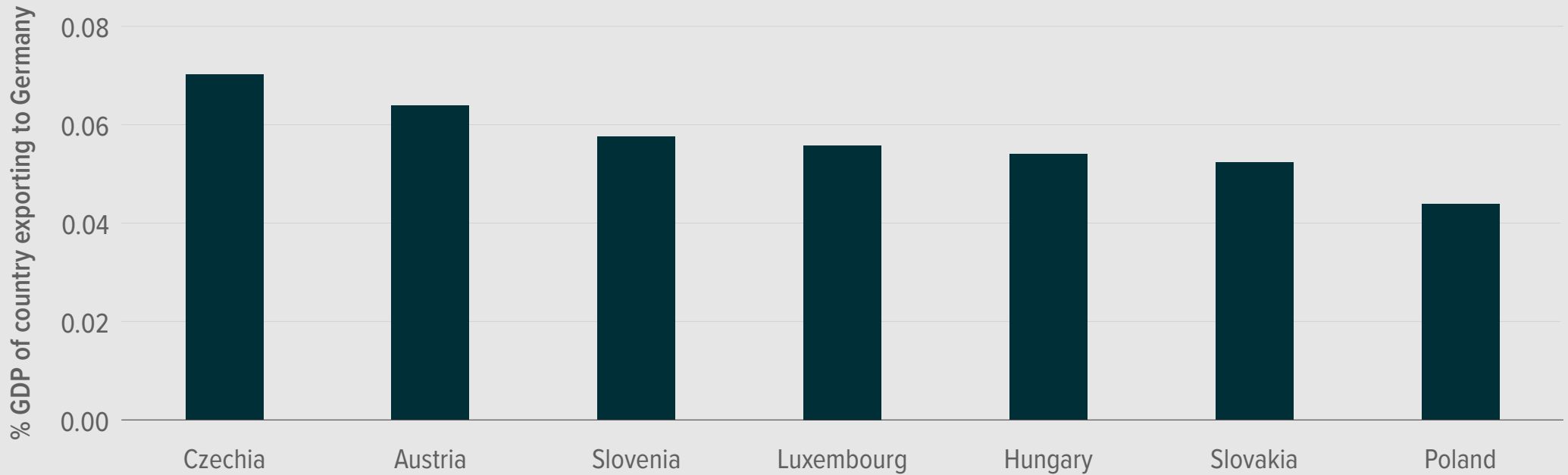

Note: We assume that spending consists of 60% construction, 30% equipment and 10% vehicles. For these sectors, we take the share of value added originating from the country providing supplies to Germany. For example, the German equipment sectors source 0.6% of their value added from Czechia, vehicles 1.1%, and construction 0.5%. Multiplying these shares by the total additional spending likely to fall on these sectors gives the total direct demand stimulus for Czechia (excluding indirect spillovers in demand, which we deal with separately. For most omitted EU countries, the estimated direct trade impact is around 0.02% to 0.03% of the supplying country's GDP.

There is no guarantee that any trends observed in this material will continue. Any views and opinions are based on current market conditions and are subject to change.



EUROPEAN INFRASTRUCTURE

Europe's Industrial Push: A New Era of Reindustrialisation?

The EU has launched the Industrial Accelerator Act, which aims to strengthen the region's industrial base by encouraging "Made in EU" production across strategic sectors such as steel, cement, aluminium, automotive manufacturing, and net-zero technologies.¹ The initiative also targets raising manufacturing's share of EU GDP to 20% by 2035, up from 14.3% in 2024.² Such policies aimed at strengthening domestic production could support demand for European manufacturers through procurement incentives and subsidies.³

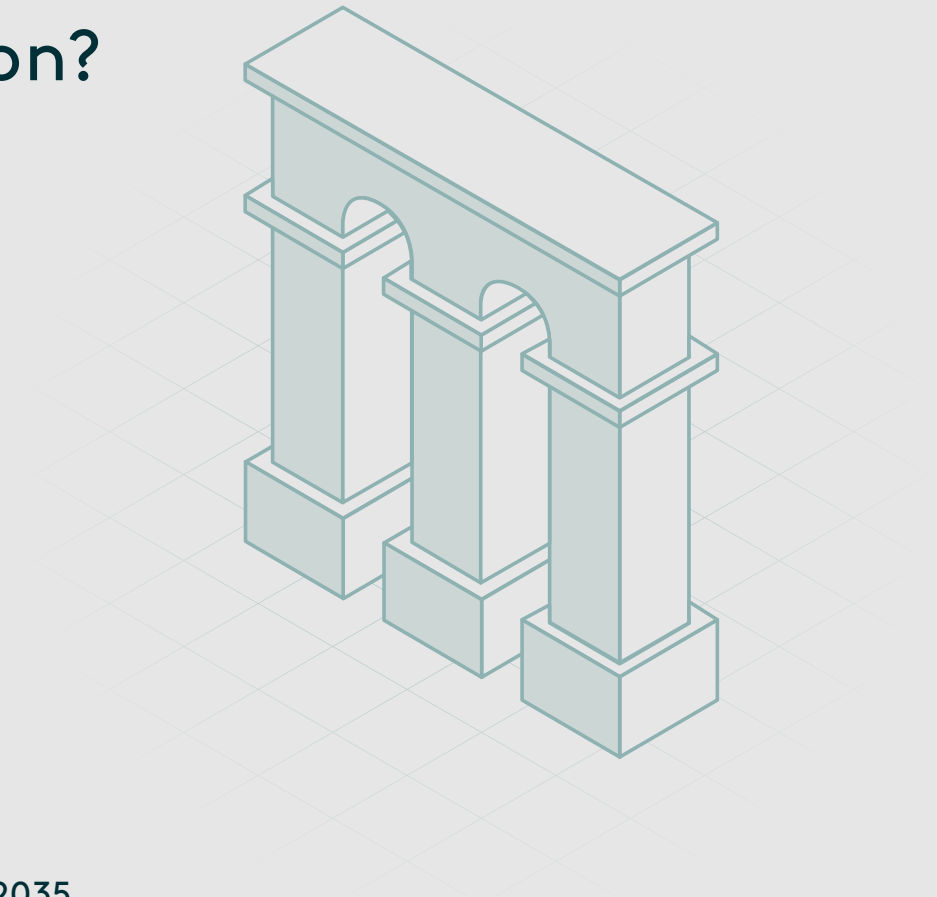

20%

Target percentage raising manufacturing's share of EU GDP by 2035



EUROPEAN INFRASTRUCTURE

Major Rail Project Awarded in Poland⁴

Construction group Ferrovial and its Polish subsidiary Budimex secured a \$699 million contract for sections of the Podłęże–Piekietko railway line, including two parallel tunnels.⁵ The railway line in southern Poland, includes 17.5 km of track, 39 bridges, and two 900m tunnels.⁶ Poland has become an increasingly important infrastructure market, representing roughly 22% of Ferrovial's order book in FY25. Poland remains one of Europe's faster-growing economies and continues to invest heavily in infrastructure.⁷ Companies with exposure to the region may benefit from a growing pipeline of transportation and development projects.

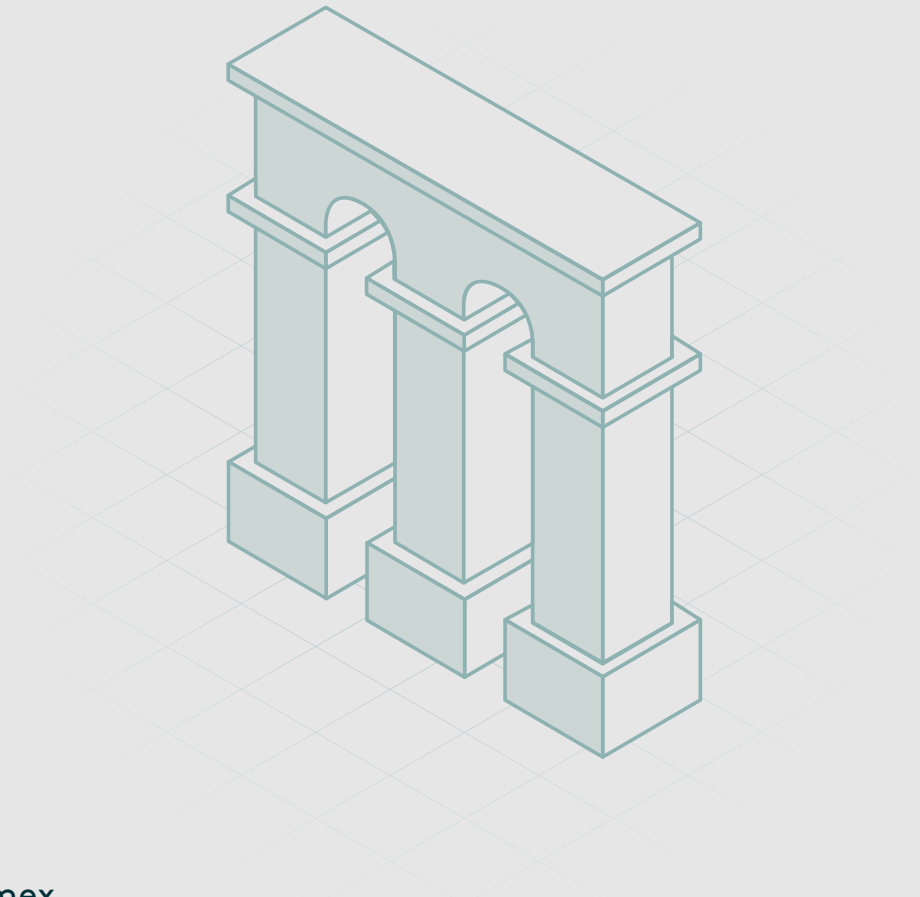

\$699_m

Value of Polish railway line project secured by Ferrovial and Budimex



DEFENCE TECH

Defence Spending Pressures: Replenishing Military Stockpiles⁸

Recent reports suggest the United States has used significant quantities of munitions amid escalating tensions around the Strait of Hormuz, with early estimates putting operational costs above \$11 billion in the first six days of strikes.⁹ Sustained military activity could potentially accelerate the depletion of existing inventories, increasing the need for replenishment. Historically, this dynamic has supported higher defence procurement budgets and longer-term demand visibility for defence manufacturers.¹⁰

\$11_{bn}

Estimated U.S. operational costs around the Strait of Hormuz in the first six days of strikes

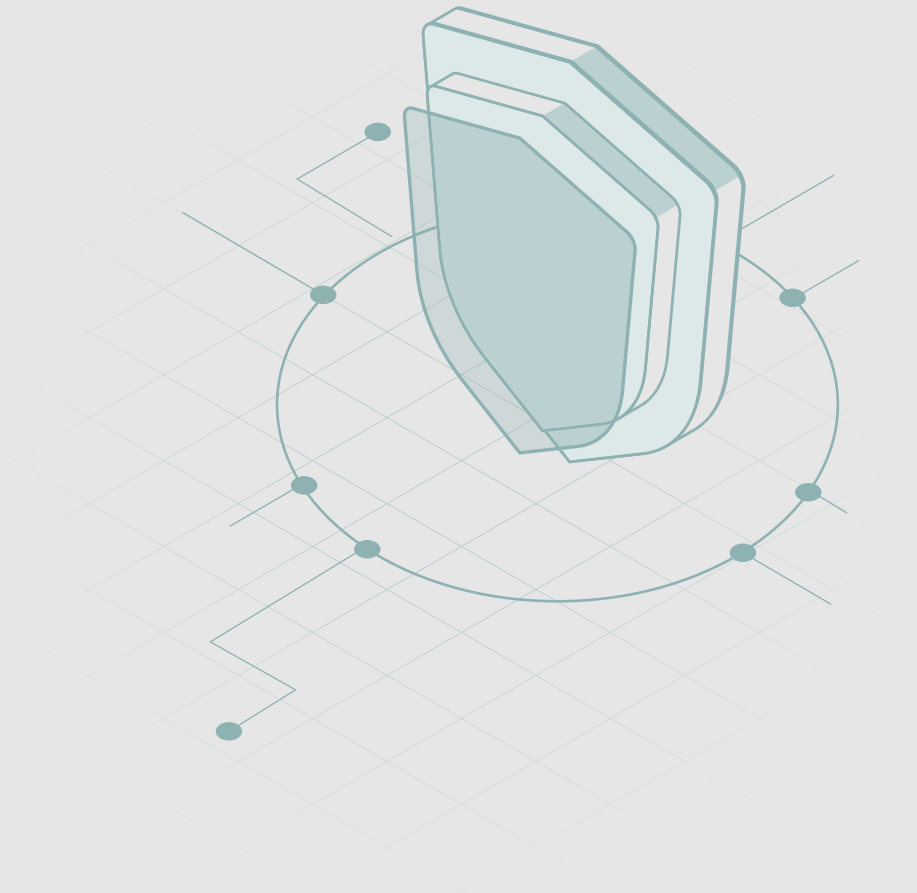



EUROPEAN DEFENCE TECH

Can Europe Build Its Own Defence Tech Ecosystem?

European defence technology start-ups are raising larger venture funding rounds, although capital from North American investors still accounts for a significant share of total funding.¹¹ A growing start-up ecosystem could potentially strengthen Europe's defence technology capabilities over time. However, the continued reliance on foreign capital highlights the gap between European and U.S. defence innovation funding.¹²





ROBOTICS & ARTIFICIAL INTELLIGENCE

Physical AI Advances: Robotics Partnerships Accelerate¹³

Chipmaker Nvidia and automation firm ABB announced a collaboration on AI-enabled robotics development, introducing a simulation platform designed to reduce costs and accelerate development cycles for industrial robots.¹⁴ Advances in AI-driven simulation and training tools could help lower barriers to deploying robotics at scale. This may accelerate automation adoption across manufacturing and logistics sectors.¹⁵

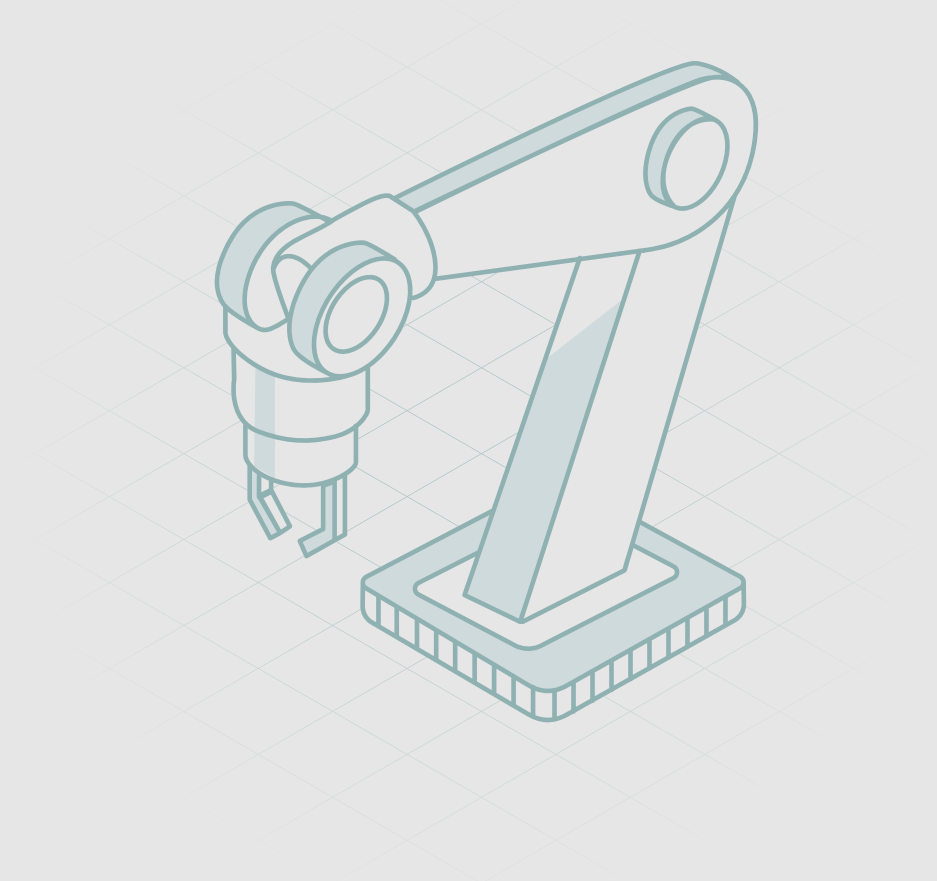



DATA CENTRES

Hyperscale Investment: Data Centre Expansion Continues¹⁶

Cloud provider Amazon reportedly plans to increase its investment in Spanish data centre infrastructure to €33.7 billion, more than doubling its previous commitment announced in 2024.¹⁷ Large-scale data centre investments appear to reflect continued growth in demand for cloud computing and AI infrastructure. Such projects may also drive secondary demand for power infrastructure, telecommunications networks, and construction services.¹⁸



€33.7_{bn}

Amazon's planned investment in Spanish data centres



FOOTNOTES

- 1 European Commission (March 2026)
- 2 Ibid
- 3 Ibid
- 4 Ferrovial (March 2026)
- 5 Ibid
- 6 Ibid
- 7 Ibid
- 8 Al Jazeera (March 2026)
- 9 New York Times (March 2026)
- 10 The International Institute for Strategic Studies (February 2025)
- 11 Financial Times (March 2026)
- 12 Bruegel (March 2026)
- 13 ABB (March 2026)
- 14 Ibid
- 15 Power & Transmission Review (March 2026)
- 16 S&P Global (January 2026)
- 17 Amazon.com (March 2026)
- 18 UN Trade & Development (January 2026)



DISCLAIMERS

This document is not intended to be, or does not constitute, investment research as defined by the Financial Conduct Authority

Important Information – Please Read Carefully

This communication is for Professional Investors only and should not be used with, nor relied upon by, retail clients. It is for use only by the recipient and should not be forwarded to a third party

The Global X UCITS ETFs are regulated by the Central Bank of Ireland.

This is a marketing communication.

The UCITS ETFs are index-tracking funds and as such you should read the investment policy of the fund in the supplement to understand how the UCITS ETF will invest.

Please refer to the relevant prospectus, supplement, and the Key Information Document (“KID”) of the relevant UCITS ETFs before making any final investment decisions.

Investors should also refer to the section entitled “Risk Factors” in the relevant prospectus of the UCITS ETFs in advance of any investment decision for information on the risks associated with an investment in the UCITS ETFs, and for details on portfolio transparency. The relevant prospectus and KID for the UCITS ETFs are available in English at www.globalxetfs.eu/funds.

Investment in the UCITS ETFs concern the purchase of shares in the UCITS ETFs and not in a given underlying asset such as a building or shares of a company, as these are only the underlying assets that may be owned by the UCITS ETFs.

A UCITS ETF's shares purchased on the secondary market cannot usually be sold directly back to a UCITS ETF. Investors must buy and sell shares on a secondary market with the assistance of an intermediary (e.g. a stockbroker) and may incur fees for doing so. In addition, investors may pay more than the current net asset value when buying shares and may receive less than the current net asset value when selling them. Changes in exchange rates may have an adverse effect on the value price or income of the UCITS ETF.

Past performance of a UCITS ETF does not predict future returns. Future performance is subject to taxation which depends on the personal situation of each investor, and which may change in the future. Neither past experience nor the current situation are necessarily accurate guides to the future growth in value or rate of return of a UCITS ETF.

Investment may be subject to sudden and large falls in value, and, if it is the case, the investor could lose the total value of the initial investment. Income may fluctuate in accordance with market conditions and taxation arrangements. The difference at any one time between the sale and repurchase price of a share in the UCITS ETF means that the investment should be viewed as medium term to long term.

Any investment in a UCITS ETF may lead to a financial loss. The value of an investment can reduce as well as increase and, therefore, the return on the investment will be variable.

Global X ETFs ICAV is an open-ended Irish collective asset management vehicle issuing under the terms of its prospectus and relevant supplements as approved by the Central Bank of Ireland and is the issuer of certain of the ETFs where stated.

Global X ETFs ICAV II is an open-ended Irish collective asset management vehicle issuing under the terms of its prospectus and relevant supplements as approved by the Central Bank of Ireland and is the issuer of certain of the ETFs where stated.

Communications issued in the European Union relating to Global X UCITS ETFs are issued by Global X Management Company (Europe) Limited (“GXM Europe”) acting in its capacity as management company of Global X ETFs ICAV. GXM Europe is authorised and regulated by the Central Bank of Ireland. GXM Europe is registered in Ireland with registration number 711633.

Communications issued in the United Kingdom and Switzerland relating to Global X UCITS ETFs are issued by Global X Management Company (UK) Limited (“GXM UK”), which is authorised and regulated by the Financial Conduct Authority. The registered office of GXM UK is 77 Coleman Street, London, EC2R 5BJ, UK. Information about GXM UK can be found on the Financial Services Register (Firm Reference Number 965081).

GXM Europe may terminate marketing arrangements.

Information for Investors in the United Kingdom

Please refer to the relevant prospectus, supplement, and the Key Investor Information Document (“KIID”) of the relevant UCITS ETFs before making any final investment decisions. These are available in English at www.globalxetfs.eu.

The Financial Ombudsman Service is unlikely to consider complaints relating to the ETF and any claims for losses relating to the manager and the Depository of the ETF are unlikely to be covered under the Financial Services Compensation Scheme.

Information for Investors in Switzerland

This is an advertising document. The state of the origin of the fund is Ireland. In Switzerland, the representative is 1741 Fund Solutions AG, Burggraben 16, CH-9000 St.Gallen. The paying agent is Telco Bank AG, Bahnhofstrasse 4, 6430 Schwyz.

The prospectus, the key information documents or the key investor information documents, the articles of association as well as the annual and semi-annual reports may be obtained free of charge from the representative.

Past performance is no indication of current or future performance. The performance data do not take account of the commissions and costs incurred on the issue and redemption of units.