



The Next Big Theme

GLOBAL X ETFs INSIGHTS

28 February 2026

Global X Investment Strategy Team

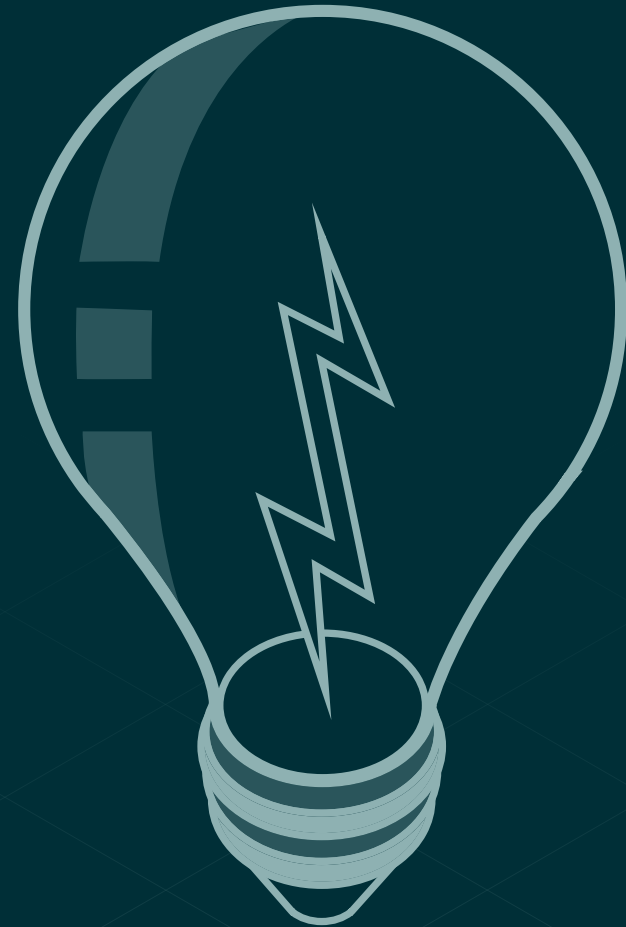

GLOBAL X
by Mirae Asset

Marketing Communication. Capital at Risk. For Professional Investors only.
Please read fund legal documentation before making any final investment decisions.



Contents



- 03 Monthly Chart Spotlight
- 04 European Defence Tech
- 05 Data Centres
- 06 Defence Tech
- 07 European Infrastructure
- 08 U.S. Infrastructure
- 09 Artificial Intelligence & Semiconductors
- 10 Footnotes
- 11 Disclaimers



MONTHLY CHART SPOTLIGHT

SPOT THE AI BOTTLENECK

Source: Global X ETFs illustration with information derived from FactSet. (21/02/2005 – 18/02//2026)

SPOT MEMORY PRICES – LTM

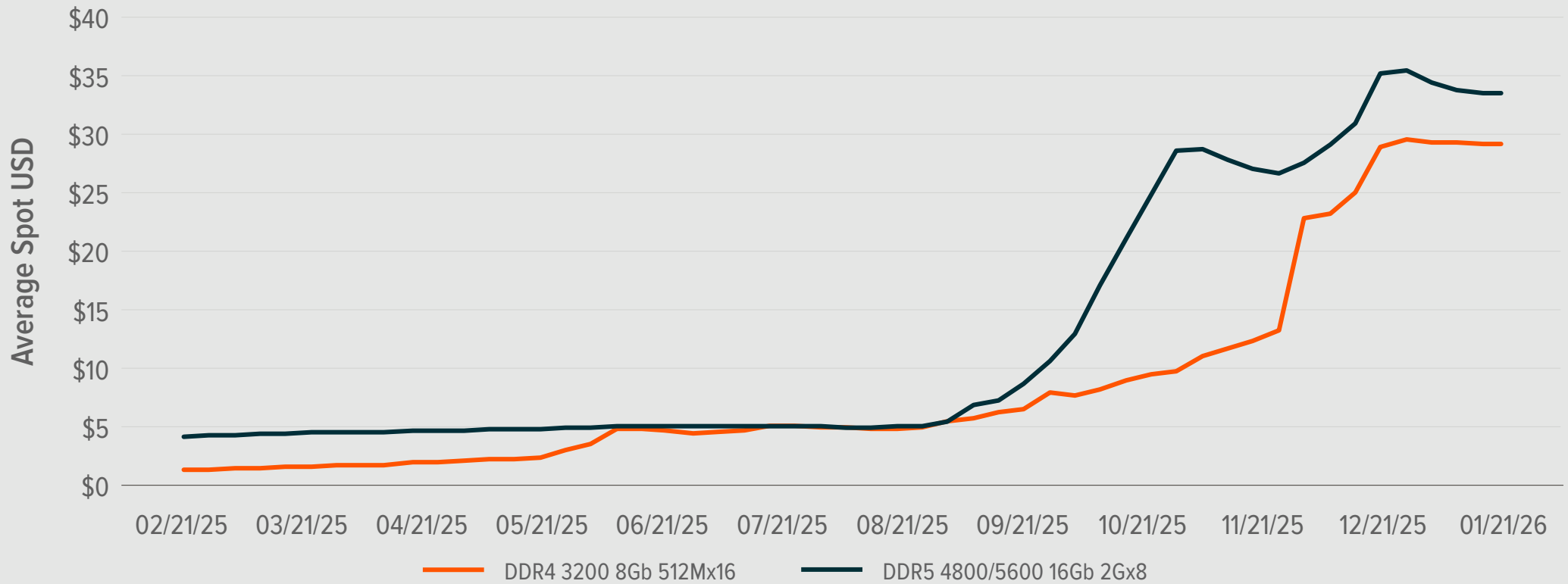

There is no guarantee that any trends observed in this material will continue. Any views and opinions are based on current market conditions and are subject to change.



EUROPEAN DEFENCE TECH

Is Europe Ready for Next-Gen Autonomous Warfare?

Europe's defence strategy appears increasingly centred on AI-enabled capability and cross-border collaboration.¹ Defence Commissioner Andrius Kubilius has called for deeper coordination among EU member states on artificial intelligence, highlighting programmes such as BraveTechEU, a joint EU-Ukraine defence tech alliance, and efforts to link battlefield innovation with Europe's defence industrial base.² The European Defence Fund has now committed €5.4 billion to 225 projects, with nearly 80% of grants in the latest round going to new innovators and more than 40% to small, high-tech companies, which appears to underline a deliberate push to broaden Europe's defence industrial base and accelerate cutting-edge technologies.³



€5.4bn

The European Defence Fund commitment to 225 projects



DATA CENTRES

How is Amazon Betting on the AI Cloud Race?

Amid a spate of employee terminations, Amazon has announced plans to massively increase its capital expenditure to approximately \$200 billion for 2026.⁴ This represents a more than 50% increase over 2025.⁵ The vast majority of this spending is earmarked for Amazon Web Services (AWS) data centres, AI chips, and networking equipment to meet surging demand for artificial intelligence and cloud computing. CEO Andy Jassy said that “the company needs the capital to keep pace with “very high demand” for Amazon’s AI compute, which requires more infrastructure such as data centers.”⁶



\$200_{bn}

Amazon’s planned capital expenditure for 2026



DEFENCE TECH



Musk Enters the AI Drone Arms Race⁷

The Pentagon is advancing AI-enabled warfare through a secretive \$100 million prize challenge focused on voice-controlled, autonomous drone swarming technology.⁸ Among the select participants are Elon Musk's companies - SpaceX and its AI subsidiary xAI – potentially marking a controversial expansion into next-generation weapons development.⁹ While SpaceX is already an established US defence contractor, the move perhaps highlights the growing convergence between frontier AI labs and military procurement, as autonomous systems become important to future battlefield strategy.¹⁰

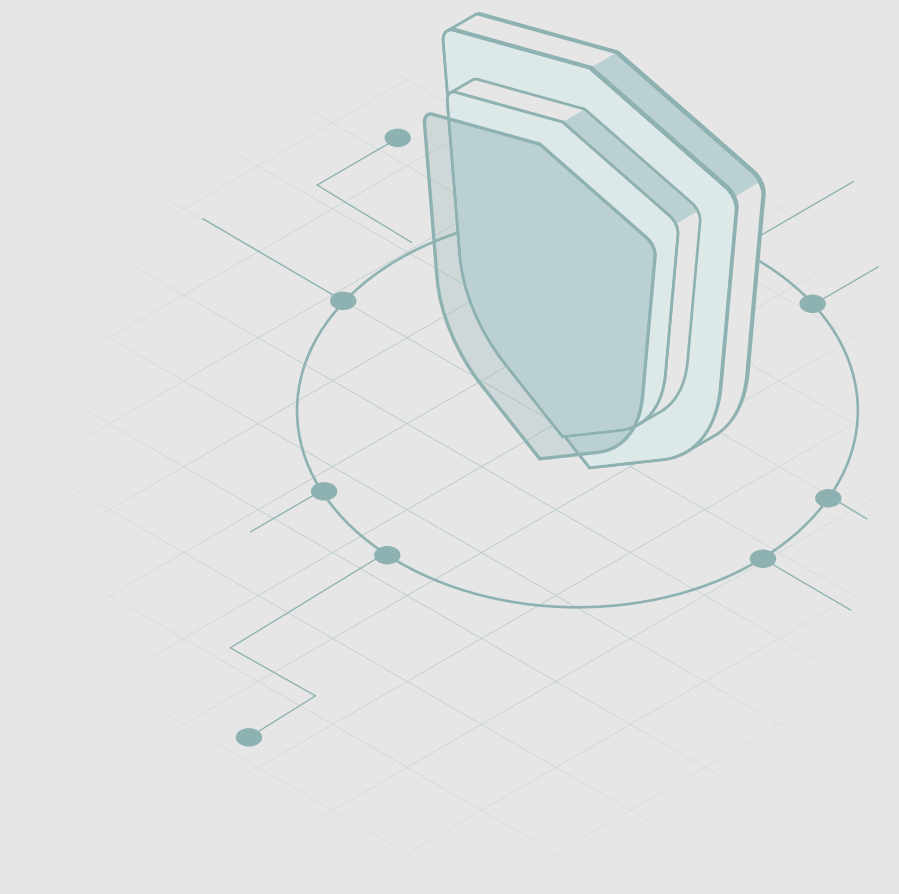

\$100_m

Challenge prize money for the Pentagon's challenge



EUROPEAN INFRASTRUCTURE

Will the Single Market Drive Europe's Infrastructure Upgrade?

The EU's push to deepen single market integration could be a major catalyst for European infrastructure.¹¹ Measures like cross-border consolidation in digital and telecom networks, combined with efforts to reduce strategic dependencies and faster capital market integration, could potentially boost domestic investment, lower financing costs, and create a broad tailwind for digital networks, energy grids, transport links, and other infrastructure projects across the continent.¹²

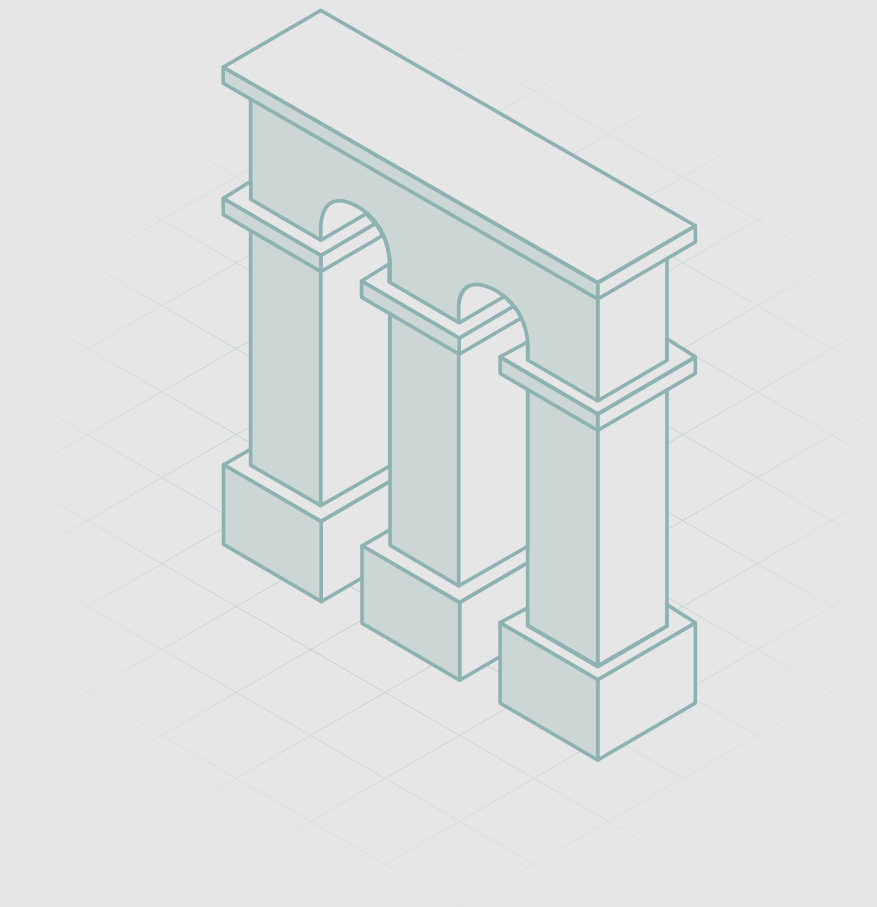



U.S. INFRASTRUCTURE

U.S. and Japan Bet Big on Energy and Minerals¹³

The United States and Japan have unveiled the first \$36 billion tranche of a broader \$550 billion trade and investment partnership, directing funds into major U.S. energy and critical minerals infrastructure.¹⁴ This includes the development of one of the largest natural gas fired power plants in Ohio, a deep water oil export terminal in Texas, and a critical materials production facility in Georgia.¹⁵ These moves are aimed at strengthening energy capacity, industrial supply chains and economic security while reducing reliance on foreign sources.¹⁶

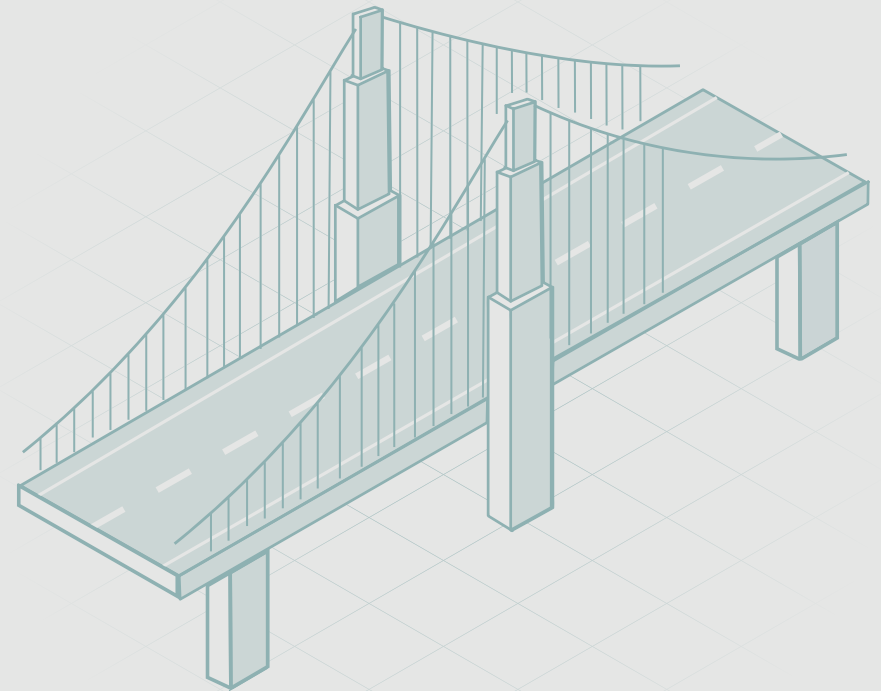

\$550_{bn}

Value of U.S. and Japan's trade and investment partnership



ARTIFICIAL INTELLIGENCE & SEMICONDUCTORS

Nvidia secures multibillion-dollar Meta deal¹⁷

Meta is doubling down on AI infrastructure, committing billions to purchase Nvidia's next-generation "Vera Rubin" chips, including standalone CPUs for the first time, amid a broader push to scale AI workloads.¹⁸ The move comes as Nvidia faces rising competition from rivals and Big Tech firms developing in-house chips, while Meta also invests in its own processors to reduce computing costs.¹⁹ The deal could potentially signal a shift from AI "training" to "inference" workloads, highlighting the growing demand for specialised hardware across the sector and reinforcing Nvidia's position in the AI data centre market.²⁰

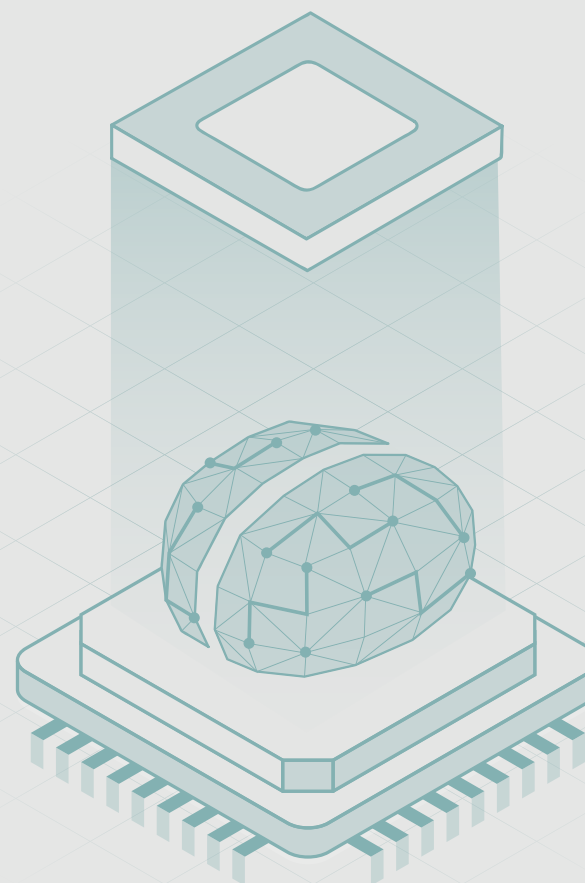



FOOTNOTES

- 1 European Relations (10/02/2026) *AI for Strategic Autonomy*
- 2 European Commission (01/02/2026) *Joint Press Release: EU and Ukraine to boost battlefield-driven solutions with BraveTech EU*
- 3 European Commission (30/01/2026) *European Defence Fund: Over €1 Billion to Drive Next-Generation Defence Technologies and Innovation*
- 4 BBC News (05/02/2026) *Amazon shares fall as it joins Big Tech AI spending spree*
- 5 Ibid
- 6 CNBC (05/02/2026) *Why Amazon's CEO is 'confident' with \$200 billion spending plan*
- 7 Bloomberg (16/02/2026) *SpaceX to Compete in Pentagon Contest for Autonomous Drone Tech*
- 8 Ibid
- 9 Ibid
- 10 Ibid

- 11 European Council (12/02/2026) *Strengthening the single market in a new geoeconomic context*
- 12 Ibid
- 13 The Guardian (18/02/2026) *US and Japan unveil \$36bn of oil, gas and critical minerals projects in challenge to China*
- 14 Reuters (17/02/2026) *Trump says Japan to invest in energy, industrial projects in Ohio, Texas and Georgia*
- 15 Ibid
- 16 Ibid
- 17 FT.com (17/02/2026) *Nvidia secures multibillion-dollar Meta deal as it battles chip rivals*
- 18 Ibid
- 19 Ibid
- 20 Ibid



DISCLAIMERS

This document is not intended to be, or does not constitute, investment research as defined by the Financial Conduct Authority

Important Information – Please Read Carefully

This communication is for Professional Investors only and should not be used with, nor relied upon by, retail clients. It is for use only by the recipient and should not be forwarded to a third party

The Global X UCITS ETFs are regulated by the Central Bank of Ireland.

This is a marketing communication.

The UCITS ETFs are index-tracking funds and as such you should read the investment policy of the fund in the supplement to understand how the UCITS ETF will invest.

Please refer to the relevant prospectus, supplement, and the Key Information Document (“KID”) of the relevant UCITS ETFs before making any final investment decisions.

Investors should also refer to the section entitled “Risk Factors” in the relevant prospectus of the UCITS ETFs in advance of any investment decision for information on the risks associated with an investment in the UCITS ETFs, and for details on portfolio transparency. The relevant prospectus and KID for the UCITS ETFs are available in English at www.globalxetfs.eu/funds.

Investment in the UCITS ETFs concern the purchase of shares in the UCITS ETFs and not in a given underlying asset such as a building or shares of a company, as these are only the underlying assets that may be owned by the UCITS ETFs.

A UCITS ETF's shares purchased on the secondary market cannot usually be sold directly back to a UCITS ETF. Investors must buy and sell shares on a secondary market with the assistance of an intermediary (e.g. a stockbroker) and may incur fees for doing so. In addition, investors may pay more than the current net asset value when buying shares and may receive less than the current net asset value when selling them. Changes in exchange rates may have an adverse effect on the value price or income of the UCITS ETF.

Past performance of a UCITS ETF does not predict future returns. Future performance is subject to taxation which depends on the personal situation of each investor, and which may change in the future. Neither past experience nor the current situation are necessarily accurate guides to the future growth in value or rate of return of a UCITS ETF.

Investment may be subject to sudden and large falls in value, and, if it is the case, the investor could lose the total value of the initial investment. Income may fluctuate in accordance with market conditions and taxation arrangements. The difference at any one time between the sale and repurchase price of a share in the UCITS ETF means that the investment should be viewed as medium term to long term.

Any investment in a UCITS ETF may lead to a financial loss. The value of an investment can reduce as well as increase and, therefore, the return on the investment will be variable.

Global X ETFs ICAV is an open-ended Irish collective asset management vehicle issuing under the terms of its prospectus and relevant supplements as approved by the Central Bank of Ireland and is the issuer of certain of the ETFs where stated.

Global X ETFs ICAV II is an open-ended Irish collective asset management vehicle issuing under the terms of its prospectus and relevant supplements as approved by the Central Bank of Ireland and is the issuer of certain of the ETFs where stated.

Communications issued in the European Union relating to Global X UCITS ETFs are issued by Global X Management Company (Europe) Limited (“GXM Europe”) acting in its capacity as management company of Global X ETFs ICAV. GXM Europe is authorised and regulated by the Central Bank of Ireland. GXM Europe is registered in Ireland with registration number 711633.

Communications issued in the United Kingdom and Switzerland relating to Global X UCITS ETFs are issued by Global X Management Company (UK) Limited (“GXM UK”), which is authorised and regulated by the Financial Conduct Authority. The registered office of GXM UK is 77 Coleman Street, London, EC2R 5BJ, UK. Information about GXM UK can be found on the Financial Services Register (Firm Reference Number 965081).

GXM Europe may terminate marketing arrangements.

Information for Investors in the United Kingdom

Please refer to the relevant prospectus, supplement, and the Key Investor Information Document (“KIID”) of the relevant UCITS ETFs before making any final investment decisions. These are available in English at www.globalxetfs.eu.

The Financial Ombudsman Service is unlikely to consider complaints relating to the ETF and any claims for losses relating to the manager and the Depository of the ETF are unlikely to be covered under the Financial Services Compensation Scheme.

Information for Investors in Switzerland

This is an advertising document. The state of the origin of the fund is Ireland. In Switzerland, the representative is 1741 Fund Solutions AG, Burggraben 16, CH-9000 St.Gallen. The paying agent is Telco Bank AG, Bahnhofstrasse 4, 6430 Schwyz.

The prospectus, the key information documents or the key investor information documents, the articles of association as well as the annual and semi-annual reports may be obtained free of charge from the representative.

Past performance is no indication of current or future performance. The performance data do not take account of the commissions and costs incurred on the issue and redemption of units.